



Project Name:	
Location:	
Item:	Qty:
Model:	

ARGF23-FD / ARGF49-FD

REACH-IN FREEZERS



ARGF23-FD



ARGF49-FD

Argus bottom mount reach-in freezers are built to last and operate efficiently for years. Temperature is digitally controlled and readily adjusted for ideal storage conditions, and easily viewed from the exterior of the cabinet. The stainless steel and aluminum construction ensures years of long life, easy to clean surfaces and maximum durability. Each appliance comes with a 6' long NEMA 5-15 cord set and includes a condensate evaporator for plug-and-play use.

FEATURES

- CFC-free polyurethane foam insulation
- 3 heavy-duty, adjustable, PE coated wire shelves per section pre-installed
- Door locks and 4" diameter swivel casters (2 w/ brakes) pre-installed
- Utilizes environmentally friendly CFC-free R404A refrigerant
- Automatic defrost system keeps the unit at peak operating condition
- Digitally controlled temperature system maintains optimum storage temperature and is easily changed when necessary.
- Self-closing doors

TEMPERATURE

- Recommended holding temperature range: 10°F to 10°F (-23° to 12°C)
- Comes factory set to 5°F (-15°C)
- Open door alert, beeps when door has been open for 3 minutes
- Alert can be set to custom time duration (30 seconds-3 minutes)
- Large evaporator and condenser for quick cooling and greater efficiency

CONSTRUCTION

- Interior lighting controlled by an automatic on-off door switch
- Stainless Steel Exterior
- Interior: Stainless steel floor and painted aluminum
- Integral condensate evaporator eliminates need for a floor drain connection
- Self contained heavy-duty refrigeration system - forced air for even temperature regulation
- Easy to grip handles formed into the door
- Heavy-duty hinges that open to 180°
- Heavy-duty corrosion-resistant shelves and adjustable mounting clips
- NEMA 5-15 6' long cord set is standard

ARGF23-FD / ARGF49-FD



Specifications subject to change without notice.

Approvals: ANSI-UL 471 and ANSI-NSF-7 Approved. DOE 2017 Compliant EPA approved insulation & refrigerant



ARGF23-FD / ARGF49-FD

REACH-IN FREEZERS

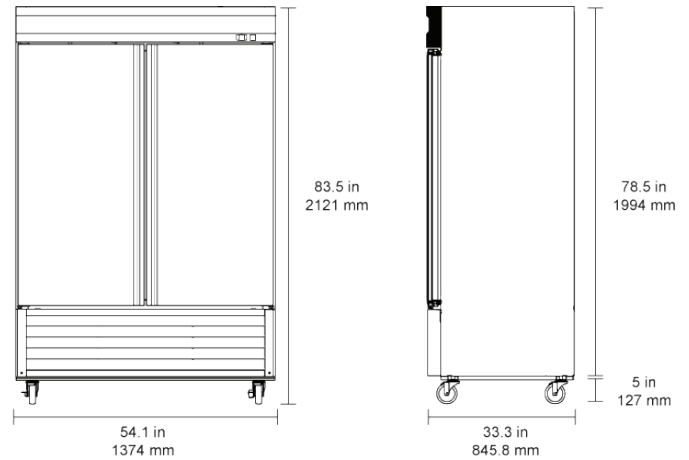
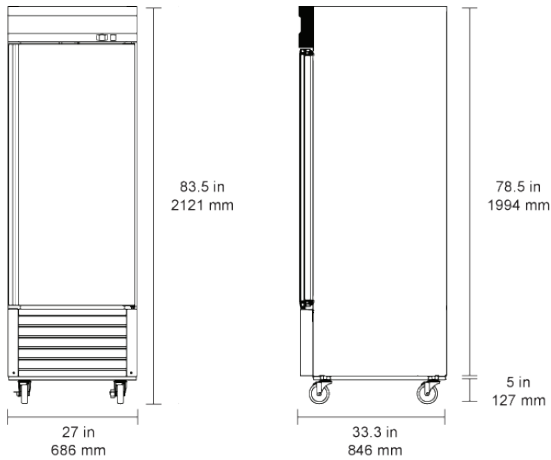
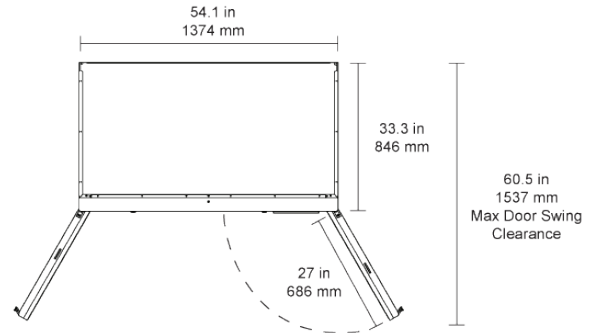
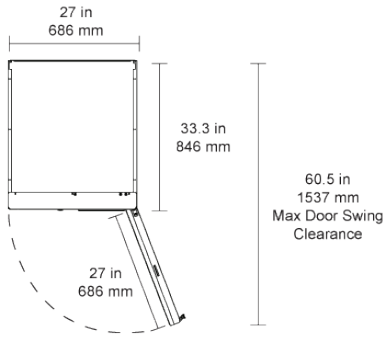

Model	Dim (W"xD"xH")	Capacity	Temp	Watts	Doors	Weight	Shelves	Average Amp Draw
ARGF23-FD	27 x 33.3 x 83.5 686 x 846 x 2121 mm	23 Cu Ft 546.5 L	-10° to 10° F -23° to -12° C	320	1	280 lb 127 kg	3	1.5
ARGF49-FD	54.1 x 33.3 x 83.5 1374 x 846 x 2121 mm	49 Cu Ft 1214.8 L	-10° to 10° F -23° to -12° C	520	2	470 lb 213 kg	6	3.7

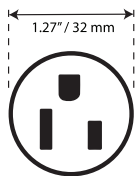

NEMA 5-15P

Comes with Nema 5-15 6' cord set as standard.
Requires a grounded circuit for safe operation.